

Effect of Line-Width Variation in Radio over Fiber System Based On Optical Single Side Band for Short Haul Communication

Abhimanyu¹, Muneet Kumar Berwal²

¹Assistant Professor, Deptt. Of ECE, Indus Institute of Engineering & Technology, Jind, India
nainabhi@gmail.com

²Research Scholar, Jind Institute of Engineering & Technology, Jind, India

Abstract

Carrier to Noise Ratio (CNR) has been investigated for radio over fiber systems including the effects of variation in the RF oscillator linewidth in this paper. Optical Single sideband signal is studied as it has tolerance for power degradation due to dispersion effects over a length of fiber. Investigations have been made out for Radio frequency of 30 GHz, with a continuous wave (CW) laser source of 1550 nm. CNR has been evaluated using Power Spectral Density(PSD) function. CNR is studied varying RF oscillator linewidth and RF oscillator linewidth for 2 Km fiber with chromatic dispersion $D=17$ ps/Km nm.

Keywords: RoF, CNR, MZM, OSSB, Power degradation.

Introduction

For satisfying the increasing capacity and data rate of subscribers, wideband communication systems are necessary in both wired and wireless link. A Radio over fiber (RoF) system is one of the most attractive systems for future broadband wireless communication having a high data rate at a microwave or millimeter wave frequency band because of the advantages of an optical fiber including the low-transmission loss and ultra wide bandwidth [1]. The volume of data traffic is ever increasing due to the demand of subscribers for voice, data, and multimedia services that require the access network to support high data rates at any time and in any place inexpensively. Generally, RoF systems transmit an optically modulated radio frequency (RF) signal from a central station (CS) to a base station (BS) via an optical fiber. The RF signal recovered using a photo detector (PD) at the BS arrives at a mobile station (MS) through a wireless channel as shown in Fig. 1. This architecture provides a cost-effective system since any RF oscillator is not required at the BS. However, the performance of RoF systems depends

on the method used to generate the optically modulated RF signal, power degradation due to fiber chromatic dispersion, nonlinearity due to an optical power level, and phase noises from a laser and an RF oscillator. Therefore, it has been a matter of concern and interest to investigate parameters that degrade the performance of RoF system.

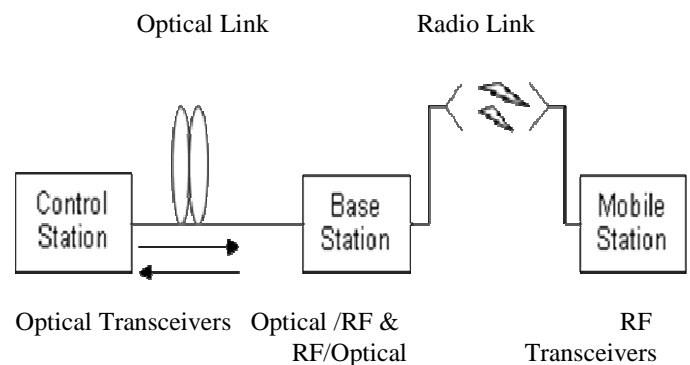

Fig. 1 Optical Link in Radio over Fiber System

Single sideband (SSB) modulation scheme is an effective way to eliminate the dispersion effects in RoF system. The power degradation due to fiber dispersion can be overcome by employing an optical single sideband modulation scheme [2]. The nonlinear effect of an optical fiber can be managed by the modulation format and control of a launched optical power [3] [4]. Unlike those parameters, a phase noise is one of practical and decisive factors in high quality services which

require high carrier to noise ratio (CNR) because it result in the bit error rate (BER) floor at high carrier to noise ratio (CNR) values [5]. This phenomenon is serious to RoF systems because the purpose of RoF systems is to provide high data rate and high quality service requiring a large carrier to noise ratio. Thus the system performance can be much sensitive to the phase noise in such services.

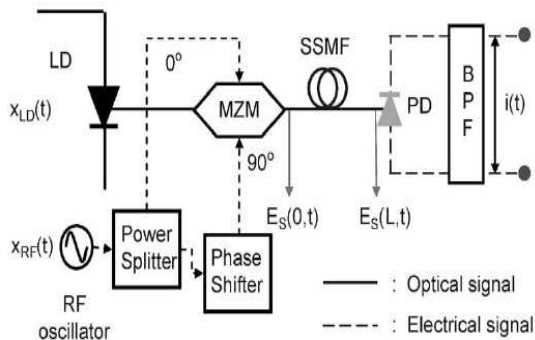

Fig. 2 Radio over Fiber system using an OSSB modulation and direct detection scheme

Here, we investigate the CNR penalty due to fiber chromatic dispersion and phase noises due to laser line width using an Optical Single Side Band (OSSB) signal and a direct-detection scheme. For the analysis of the Carrier to noise ratio penalty, the autocorrelation and the power spectral density function of a received photocurrent are evaluated. The bandwidth of an electrical filter is dealt in the CNR penalty since the phase noises result in an increase of the required bandwidth and the increased bandwidth causes an additional Carrier to noise ratio penalty. It is shown that the phase noise due to the laser line width is the dominant parameter in a large optical distance.

RoF System Based on Optical Single Side Band & Direct Detection

An Optical Single Side Band (OSSB) signal is generated by using Dual electrode mach zehender modulator (MZM) and a phase shifter. An RF signal from an oscillator is split by a power splitter and a 90° phase shifter. This RF signal is optically modulated by the Laser Diode (LD) with an MZM. The optically modulated signal is transmitted to the PD and the photocurrent corresponding to the transmitted RF signal is extracted by the BPF as in Fig. 2. First, the optical signals from the optical source, laser diode and the RF oscillator are modeled as:

$$x_d(t) = A^d \cdot \exp j(\omega_d t + \Phi_d(t)) \quad (1.1)$$

$$x_o(t) = V_o \cdot \cos(\omega_o t + \Phi_o(t)) \quad (1.2)$$

Where A^d and V_o define amplitudes from the optical source and the RF oscillator signal, ω_d and ω_o define angular frequencies of the signals from the LD and the RF oscillator, and $\Phi_d(t)$ and $\Phi_o(t)$ are phase-noise processes. The OSSB signal generated using Dual electrode MZM is modeled in equation (3).

$$E_{SS}(0,t) \cong A^d L_{MZM} \left\{ \begin{array}{l} J_0(\alpha\tau) \exp j \left[\omega_d t + \Phi_d(t) + \frac{\pi}{4} \right] - \sqrt{2} J_1(\alpha\tau) \\ \exp j \left[\omega_d t + \Phi_d(t) + \omega_o t + \Phi_o(t) \right] \end{array} \right\} \quad (1.3)$$

After the transmission of signal over L km fiber, the signal can be represented as equation (4) & in this equation L_{add} denotes an additional loss in the optical link, α_{fiber} is the SSMF loss, L_{fiber} is the transmission distance of the SSMF, and τ_0 and τ_+ define group delays for a center angular frequency of ω_d and an upper sideband frequency of $\omega_d + \omega_o$. ϕ_1 and ϕ_2 are phase-shift parameters for specific frequencies due to the fiber chromatic dispersion.

$$E_{SS}(L,t) \cong \left\{ \begin{array}{l} A^d L_{MZM} L_{add} \cdot 10^{-\frac{\alpha_{fiber} L_{fiber}}{20}} J_0(\alpha\tau) \\ \exp j \left[\omega_d t + \Phi_d(t - \tau_0) - \phi_1 + \frac{\pi}{4} \right] \frac{\sqrt{2} J_1(\alpha\tau)}{J_0(\alpha\tau)} \\ \exp j \left[\omega_d t + \Phi_d(t - \tau_+) + \omega_o t + \Phi_o(t - \tau_+) - \phi_2 \right] \end{array} \right\} \quad (1.4)$$

To evaluate the CNR, we utilize the autocorrelation function and the PSD of the photocurrent.

$$i(t) \cong \eta |E_{SS}(L,t)|^2 \quad (1.5)$$

Where η defines the responsivity of the PD and $| \cdot |^2$ is the square-law detection.

$$i(t) \cong \eta |A^d|^2 \left\{ B + 2\alpha \cos \left[\begin{array}{l} \Phi_d(t - \tau_+) - \Phi_d(t - \tau_0) \\ + \omega_o t + \Phi_o(t - \tau_+) - \phi_2 + \phi_1 \end{array} \right] \right\} \quad (1.6)$$

Where $A_1^d = A^d \cdot L_{MZM} \cdot L_{add} \cdot 10^{-\frac{\alpha_{fiber} L_{fiber}}{20}} J_0(\alpha\tau)$

$$\alpha_1 = \frac{\sqrt{2}J_1(\alpha\pi)}{J_0(\alpha\pi)} \text{ and } B = 1 + \alpha_1^2$$

The autocorrelation function $R_I(\tau)$ is obtained as

$$R_I(\tau) = \langle i(t) \cdot i(t + \tau) \rangle \quad (1.7)$$

Now we will evaluate PSD function which is Fourier transform of $R_I(\tau)$

$$S_1(f) = F \langle R_I(\tau) \rangle \quad (1.8)$$

Where

$$S_1(f) = R_I(\tau) \int_{-\infty}^{\infty} R_I(\tau) d\tau^* \exp(-j\tau\omega) \quad (1.9)$$

In equation (9), the first term represents a dc component, the second and third is the broadening effects due to the fiber chromatic dispersion and the line widths of the laser and the RF oscillator. the second term was only a carrier to noise penalty due to the fiber chromatic dispersion. Now the received RF carrier Power P_1 is approximately represented as follows

$$P_1 = 2 \int_{f_o - \frac{B_o}{2}}^{f_o + \frac{B_o}{2}} S_1(f) df \quad (1.10)$$

By using (9), received RF carrier power P_1 as

$$P_1 \cong \frac{4\eta^2 A_1^{d4} \alpha_1^2}{\pi} \exp(-2\Upsilon_i |\tau|) \tan^{-1} \left(\frac{\pi \cdot B_o}{2\Upsilon_o} \right) \quad (1.11)$$

The CNR induced by the differential delay from the fiber chromatic dispersion and the line widths from the laser and the RF oscillator is found

$$CNR = \frac{\text{CarrierPower}}{\text{NoisePower}} \quad (1.12)$$

$$CNR \cong \frac{P_1}{2B_o \cdot \left(\frac{N_o}{2} \right)} \\ CNR \cong \frac{2\eta^2 A_1^{d4} \alpha_1^2 p}{N_o \cdot \left(\frac{\Upsilon_o}{\pi} \right) \tan \left(\frac{\pi \cdot p \exp(-2\Upsilon_i |\tau|)}{2} \right)} \quad (1.13)$$

Where $\eta = \text{responsivity}$, $A_1^d =$ constant related to the laser light amplitude A and the losses in fibre, MZM and the joint and splices given by $\alpha_1 = \frac{\sqrt{2}J_1(\alpha\pi)}{J_0(\alpha\pi)}$ $J =$ Bessel function of 1st kind, of order n and $\alpha_1 =$ normalized RF voltage given by $\alpha_1 = \frac{V_{rf}}{V_\pi}$ Where A_1^d is the amplitude of laser light, L_{MZM} is the lose in the MZM, L_{add} is the factor accounting for the additional loss in the fiber, α_{fiber} is the loss in the fiber and L_{fiber} is the length of fiber. V_{rf} is the input RF voltage and V_π is the MZM switching voltage, p is the ratio of the power required for a particular filter used to the total carrier power. This parameter incorporates the effect of the bandwidth of the filter being used. And N_o is the additive white Gaussian noise power spectral density. The parameters $2\Upsilon_{LD} = 2\pi\Delta\nu_{LD}$ and $2\Upsilon_{RF} = 2\pi\Delta\nu_{RF}$, define the angular full-linewidth at half maximum (FWHM) of the Lorentzian shape for the laser and the RF oscillator. And $2\Upsilon_e = 2\pi\Delta\nu_{LD} + \pi\Delta\nu_{RF}$ gives the total linewidth. $\tau = \tau_c \pm \tau_d$ is the differential delay due to the fiber chromatic dispersion and is given by $\tau = D \cdot L_{fiber} \cdot \lambda^2 \cdot \frac{f_{RF}}{c}$ Where D is the fiber chromatic dispersion parameter, L_{fiber} is the fiber length, f_{RF} is the RF frequency and c is the speed of light.

Result and Discussion

CNR is evaluated and resulting values are simulated to study and realize the importance RF oscillator linewidth on CNR which can be seen from the resulting plot. The effect of the RF oscillator linewidth on the CNR of the system is shown in the figure 3. Here, CNR is plotted against the RF oscillator linewidth for three different values of laser line width viz. 100MHz, 250MHz and 500MHz. The first parameter is the photodiode responsivity \mathfrak{R} . For most of the photo diodes its values is between 0.3 to 0.8. Taking the value of R as 0.4 [11]. Now the second constant is A_1 which in tem depend upon other parameters given as

$$A_1 = A \cdot L_{MZM} \cdot L_{add} \cdot 10^{\frac{-\alpha_{fiber} L_{fiber}}{20}} \cdot J_0(\alpha\pi) \\ = V_{rf} / V_\pi$$

Here L_{MZM} is the loss of the DE- MZM. Now considering the MZM as a integrated waveguide power splitter and combiner, its value can be assumed to be negligible (which is true for small lengths of the waveguide). L_{add} is the additional loss caused by the fiber components such as the splices, joints etc. Its value for a 2 Km fiber link can be taken as approximately 3 dB. α_{fiber} is the loss per Km of the fiber and is around .2dB/Km for SSMF. L_{fiber} is the length of the fiber

and is equal to 10 Km for this case. α is the modulation index of the MZM and is equal to $\alpha = V_{rf}/V_{\pi}$. Now taking $V_{rf}=1\text{mV}$ and $V_{\pi}=2.2\text{V}$, we obtain $\alpha=0.00045$ then the modulation index is given as $\alpha\pi=0.0014$. It gives $J_0(\alpha\pi)$ equal to 1 approximately. From above all, the value of A1 is calculated as 0.1342. N_0 is the power spectral density of the AWGN for very low noise case, it can be taken as 10^{-11} . Now $\alpha 1$ depends upon the first harmonic of the photo detector and the fundamental component. So the value of $\alpha 1$ is 0.001. Thus all

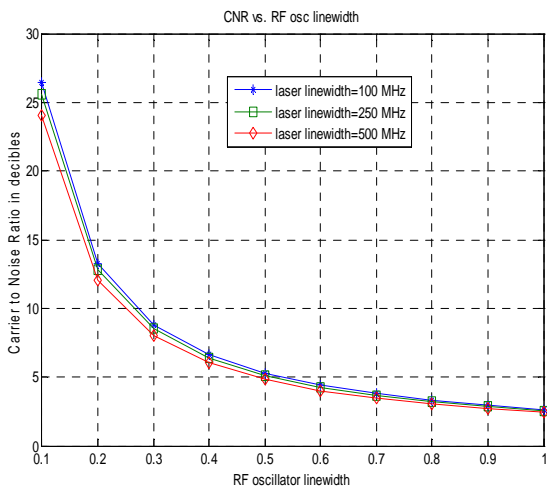

Fig. 3 CNR in dB vs. RF oscillator linewidth

the constants terms are evaluated, then CNR is studied including the effects of the RF oscillator line width. When we vary the plot for different values of laser oscillator linewidth which are taken 100 MHz, 250 MHz and 500 MHz variations are very minute showing the system to be less dependent on RF oscillator linewidth for long haul communication.

Conclusion

CNR has been investigated due to the variation in the RF oscillator linewidth. Here a direct detection for cost effectiveness has been used. It is evident that the CNR decreases as the linewidth of the RF oscillator increases.

References

- [1] P. Smolders, "Exploiting the 60 GHz Band for Local Wireless Multimedia Access: Prospects and Future Directions," *IEEE Commun. Mag.*, Jan. 2002, pp. 140–147.
- [2] G. H. Smith and D. Novak, "Overcoming chromatic-dispersion effects in fiber-wireless systems incorporating external modulators," *IEEE Trans. Microw. Theory Tech.*, Vol. 45, No. 8, Aug. 1997, pp. 1410–1415.
- [3] J. Leibrich, "CF-RZ-DPSK for suppression of XPM on dispersion managed long-haul optical WDM transmission on standard single-mode fiber," *IEEE Photon. Technol. Lett.*, Vol. 14, No. 2, Feb. 2002, pp. 155–157.
- [4] Y. J. Wen, "Power level optimization of 40 Gb/s DWDM systems with hybrid Raman/EDFA amplification," in *Proc. Conf. Optical Internet/Australian Conf. Optical Fibre Tech. (COIN/ACOFT)*, Melbourne, Australia, Jul. 2003, pp. 309–312.
- [5] J. R. Barry and E. A. Lee, "Performance of coherent optical receivers," *Proc. Inst. Elect. Eng.*, Vol. 78, No. 8, Aug. 1990, pp. 1369–1394.
- [6] P. B. Gallion and G. Debarge, "Quantum phase noise and field correlation in single frequency semiconductor laser systems," *IEEE J. Quantum Electron.*, vol. QE-6, no. 4, pp. 343–349, Apr. 1984.